

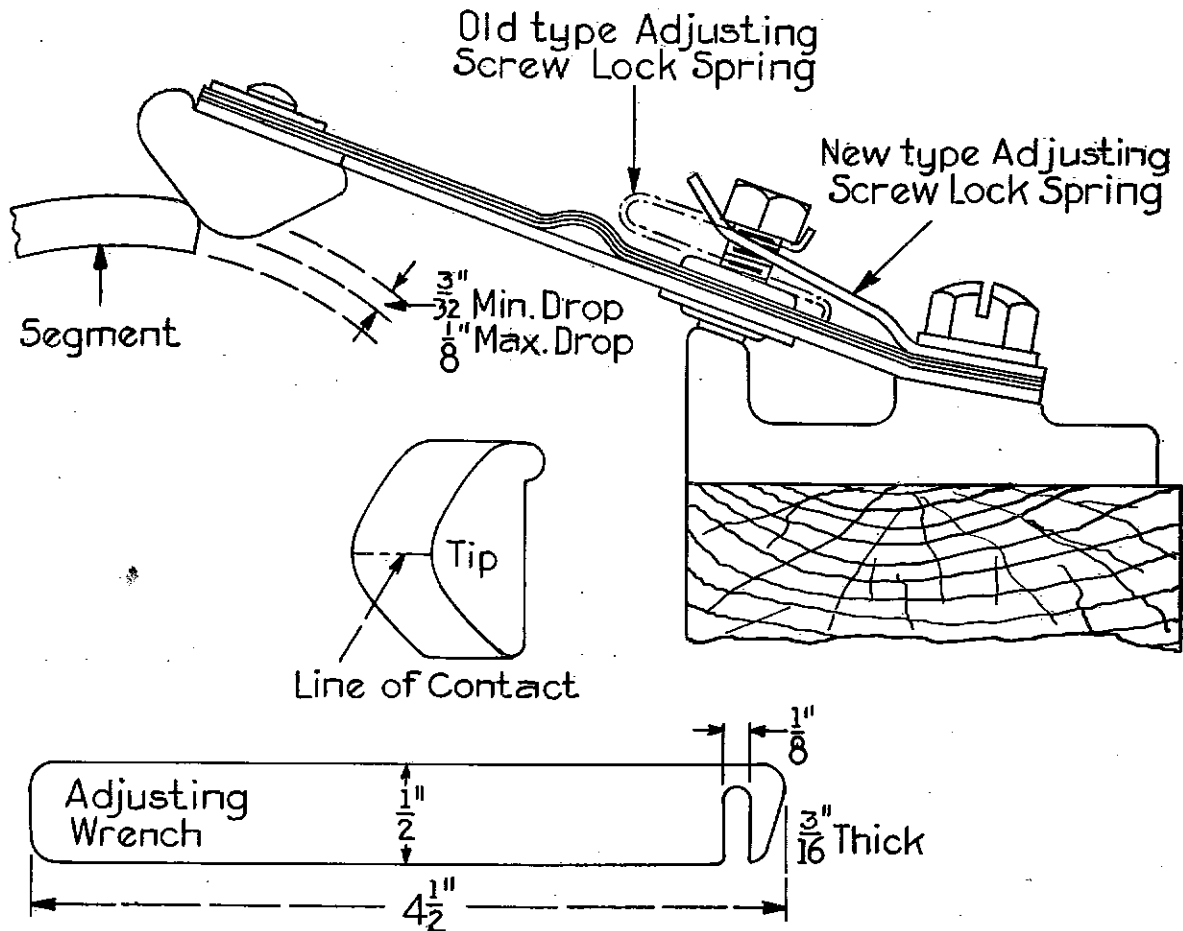

# Adjustment of Drum Controller Fingers



Each finger of a drum controller is provided with an adjusting screw for limiting the movement of the finger as the tip breaks contact with the segment. This movement should not exceed  $\frac{1}{8}$  in. at the tip for easy operation of the controller and reasonable wear of fingers and segments, but must be at least  $\frac{3}{32}$  in. for proper contact. The  $\frac{3}{32}$ -in. movement should be carefully checked in adjusting new fingers to operate on worn segments. If proper adjustments cannot be made, the segments are probably worn out and should be replaced.

The contact line of the finger tip should touch the segment at all points. If contact is not made all along this line, the finger should be twisted until such contact is made. If this is not done, both the finger and segment will overheat, causing the finger spring to soften and lose its tension. An adjusting wrench similar to the one illustrated above is useful in twisting the finger, so that the tip will make proper contact with the segment. This wrench will fit over the finger spring and shunt just back of the finger tip.

The tip should bear on the segment with a 6-pound pressure, measured at the line of contact.

*Ask our nearest office for complete information*

**General Electric Company, Schenectady, N. Y.**

SALES OFFICES IN ALL LARGE CITIES